

LM2419 Triple 65 MHz CRT Driver

General Description

The LM2419 contains three wide bandwidth, large signal amplifiers designed for large voltage swings. The amplifiers have a gain of -15 . The device is intended for use in color CRT monitors and is a low cost solution to designs conforming to 1024 x 768 display resolution.

The device is mounted in the industry standard 11-lead TO-220 molded power package. The heat sink is electrically isolated and may be grounded for ease of manufacturing and EMI/RFI shielding.

Features

- 50 V_{PP} output swing at 65 MHz
- Rise/Fall time 5 ns with 12 pF load
- 60 V_{PP} output swing capability
- Pin and function compatible with LM2416
- No low frequency tilt compensation required

Applications

- CRT driver for SVGA, IBM 8514 and 1024 x 768 display resolution RGB monitors

Schematic and Connection Diagrams

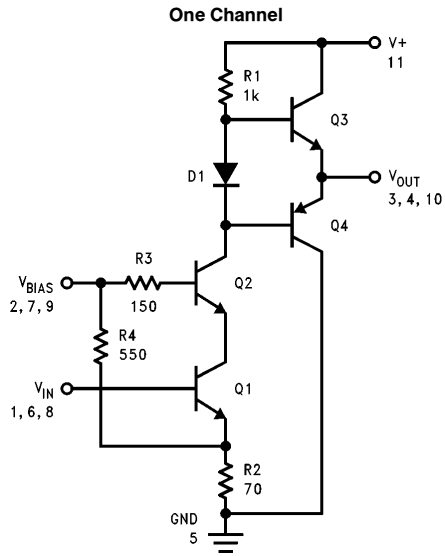

TL/H/11442-1

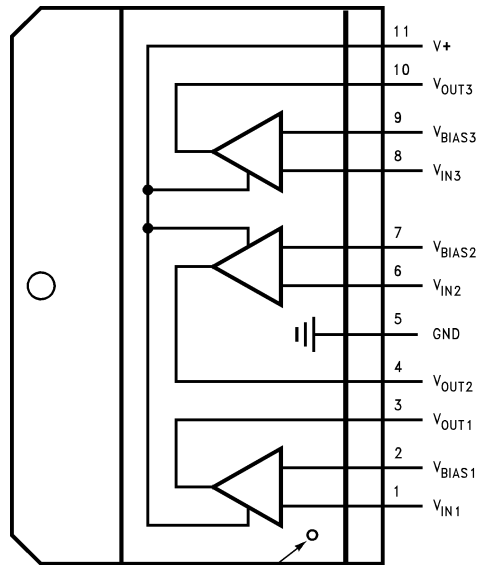

TL/H/11442-2

Order Number LM2419T
See NS Package Number TA11B

Absolute Maximum Ratings (Note 1)

If Military/Aerospace specified devices are required, please contact the National Semiconductor Sales Office/Distributors for availability and specifications.

Supply Voltage (V^+)	+85V
Storage Temperature (T_{STG})	-25°C to +100°C
Operating Case Temperature, T_{Case}	-20°C to +90°C
Lead Temperature (soldering <10 sec.)	300°C
ESD Tolerance	2 kV

Electrical Characteristics

Unless otherwise specified, the following specifications apply for $V^+ = 80V$, DC input bias, $V_{IN DC} = 3.9V$; 50 V_{PP} output swing; frequency = 1 MHz; $V_{Bias} = 12V$; $C_L = 12 pF$; $T_A = 25°C$; see test circuit, Figure 1.

Symbol	Parameter	Conditions	Min (Note 3)	Typ (Note 2)	Max (Note 3)	Units (Limit)
I_{CC}	Supply Current (per Amplifier)	Input/Output Open Circuit		27	40	mA
I_B	Bias Current (Pins 2 or 7 or 9)			11		mA
V_{OUT}	Output Offset Voltage		40	50	60	V
t_r	Rise Time	10% to 90%		5		ns
t_f	Fall Time	90% to 10%		5		ns
A_V	Voltage Gain		-13	-15	-18	V/V
OS	Overshoot	V_{IN} : $t_r, t_f < 2 ns$		8		%
LE	Linearity Error	$V_{OUT} = 25V$ to $75V$		8		%
ΔA_V match	Gain Matching			0.3		dB

Note 1: Absolute Maximum Ratings indicate limits beyond which damage to the device may occur. The guaranteed specifications apply only for the test conditions listed. Some performance characteristics may degrade when the device is not operated under the listed test conditions.

Note 2: Typical specifications are at 25°C and represent the most likely parametric norm.

Note 3: Min/Max limits are guaranteed to National's AOQL (Average Outgoing Quality Level).

Typical Performance Characteristics

$T_A = 25°C$, Test Circuit—Figure 1

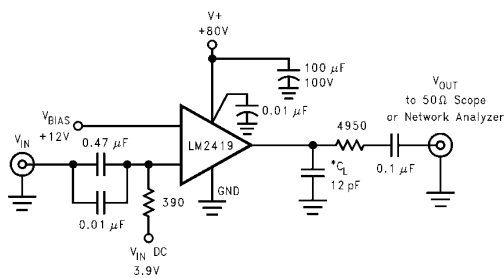

TL/H/11442-3

*12 pF is the total load capacitance and includes the test fixture capacitance.

FIGURE 1. Test Circuit (One Section)

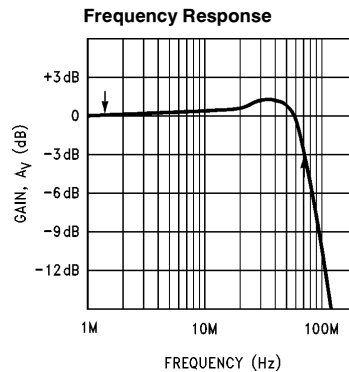

TL/H/11442-4

Typical Performance Characteristics (Continued)

$T_A = 25^\circ\text{C}$, Test Circuit—Figure 1

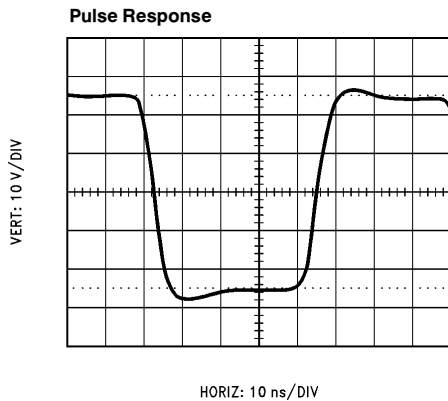

Test Circuit

Figure 1 shows a typical test circuit for evaluation of the LM2419. The input signal is AC coupled into the input of LM2419 and is referenced to 3.9V DC using an external 3.9V DC bias through a 390 Ω resistor. The test circuit is designed to allow testing of the LM2419 in a 50 Ω environment such as a 50 Ω oscilloscope or network analyzer. The 4950 Ω resistor in series with the output of the LM2419 forms a 100:1 voltage divider when connected to a 50 Ω oscilloscope or network analyzer.

Theory of Operation

The LM2419 is a high voltage triple CRT driver suitable for SVGA, IBM 8514 and 1024 x 768 display resolution monitors. The device is packaged in the industry standard 11 lead TO-220 molded power package. The heat sink is electrically isolated and may be grounded for ease of manufacturing and RFI/EMI shielding.

The schematic diagram of LM2419 is shown in Figure 2. Q1 and R2 provide a conversion of the input voltage to current while Q2 acts as a common base amplifier to drive the load resistor, R1. Resistor R4 along with R2 sets up the DC bias at the base of Q1. Emitter followers Q3 and Q4 isolate R1 from the capacitive load at the output, thus making the rise and fall times relatively insensitive to the load capacitance.

The gain of the amplifier is $-R1/(R2 \parallel R4)$ and is fixed at approximately -15. The bandwidth of LM2419 is primarily limited by the time constant due to R1 and the capacitances associated with D1, Q2, Q3 and Q4. Diode D1 is used to provide some bias voltage for Q3 and Q4 so as to reduce

small signal cross over distortion. Resistor R3 is used to prevent Q2 from oscillating at high frequencies.

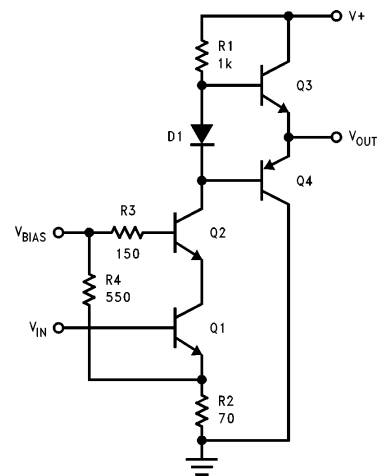

FIGURE 2. Schematic Diagram of One Section of LM2419

Application Hints

POWER SUPPLY BYPASS

Since the LM2419 is a wide-bandwidth amplifier with greater than 10,000 V/ μs slew rate, proper power supply bypassing is critical for optimum performance. Improper power supply bypassing can result in large overshoot, ringing and oscillation. A 0.01 μF ceramic capacitor should be connected as close to the supply pin as is practical (preferably less than 1/4" from the supply pin). The lead length of the 0.01 μF ceramic capacitor should be as small as is practical. In addition, 10 μF –100 μF electrolytic capacitor should be connected from the supply pin to ground. The electrolytic capacitor should be placed reasonably close to the LM2419's supply pin.

ARC PROTECTION

The LM2419 must be protected from arcing within the CRT. To limit the arcover voltage, a 200V spark gap is recommended at the cathode. Clamp diodes D1 and D2 (as shown in Figure 3) are used to clamp the voltage at the output of LM2419 to a safe level. The clamp diodes used should have high current rating, low series impedance and low shunt capacitance. Resistor R2 in Figure 3 limits the arcover current while R1 limits the current into LM2419 and reduces the power dissipation of the output transistors when the output is stressed beyond the supply voltage. Having large value resistors for R1 and R2 would be desirable but this has the effect of reducing rise and fall times.

Application Hints (Continued)

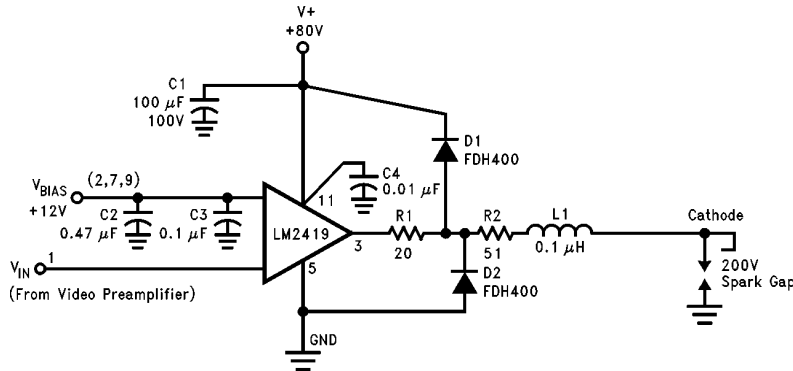

FIGURE 3. Typical Application Circuit (One Channel)

TL/H/11442-8

IMPROVING RISE AND FALL TIMES

Because of an emitter follower output stage, the rise and fall times of the LM2419 are relatively unaffected by capacitive loading. However, the series resistors R1 and R2 (see *Figure 3*) will reduce the rise and fall times when driving the CRT's cathode which appears as a capacitive load. The capacitance at the cathode typically ranges from 8 pF to 12 pF.

To improve the rise and fall times at the cathode, a small inductor is often used in series with the output of the amplifier. The inductor L1 in *Figure 3* peaks the amplifier's frequency response at the cathode, thus improving rise and fall times. The inductor value is empirically determined and is dependent on the load. An inductor value of 0.1 µH is a good starting value. Note that peaking the amplifier's frequency response will increase the overshoot.

REDUCING OVERSHOOT

LM2419's overshoot is a function of both the input signal rise and fall times and the capacitive loading. The overshoot is increased by either more capacitive loading or faster rise and fall times of the input signal.

Table I shows the overshoot for a typical device with different capacitive loads and different input signal rise and fall times. As can be observed from Table I, overshoot is large for large capacitive loads and faster input signal rise and fall times. In an actual application, the LM2419 is driven from a preamplifier with rise and fall times of 3 ns to 7 ns. When driven from LM1203 preamplifier (see application circuit, *Figure 6*) the overshoot is 10% with 12 pF capacitive load. The overshoot can be reduced by including a resistor in series with LM2419's output as in *Figure 3*. Larger value resistors for R1 and R2 would reduce overshoot but this also increases the rise and fall times at the output. Frequency peaking using an inductor in series with the output may restore the bandwidth.

Table I. LM2419 Output Overshoot vs Capacitive Loading for a Typical Device

Input Signal t_r/t_f	C_L			
	5 pF	8 pF	11 pF	15 pF
1.2 ns	4%	6%	7%	8%
7 ns	4%	5%	6%	7%

GAIN VS OUTPUT DC LEVEL

Figure 4 shows LM2419's gain versus output DC level. A 100 mV_{PP} AC signal is applied at the LM2419's input and the input signal's DC level is swept. As can be seen from *Figure 4*, the amplifier's gain is constant at approximately 15.4 ($V_{OUT} = 1.54 V_{PP}$) for output DC level between 35V and 65V. Thus the amplifier's output response is linear for output voltage between 35V and 65V. If the output voltage is less than 35V or more than 70V, the amplifier's output response becomes non-linear (note the change in gain, *Figure 4*). For optimum performance, it is recommended that LM2419's output low voltage be at 25V or above. For a 50 V_{PP} swing, the output high voltage is 75V. With an output signal swing from 25V to 75V, LM2419's linearity error is measured at 8%.

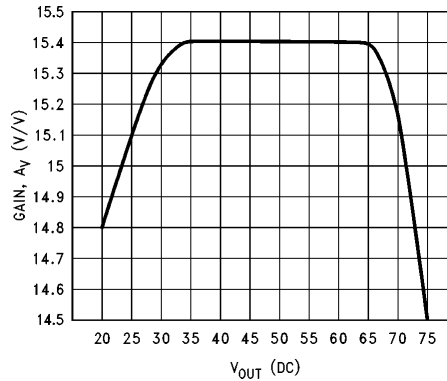

TL/H/11442-9

FIGURE 4. Gain vs V_{OUT} (DC), $V_{IN} = 100 \text{ mV}_{PP}$

Application Hints (Continued)

THERMAL CONSIDERATIONS

LM2419's transfer characteristic and power dissipation versus DC input voltage is shown in *Figure 5*. Power supply current increases as the input voltage increases, consequently power dissipation increases. For the LM2419, the worst case power dissipation occurs when a white screen is displayed on the CRT. Considering a 20% black retrace time in a 1024 x 768 display resolution application, the average power dissipation for continuous white screen is less than 4W per channel with 50 V_{PP} output signal (black level at 75V and white level at 25V). Although the total power dissipation is less than 12W for a continuous white screen, the heat sink should be selected for 13W power dissipation because of the variation in power dissipation from part to part.

For thermal and gain linearity considerations, the output low voltage (white level) should be maintained above 20V. If the device is operated at an output low voltage below 20V, the power dissipation might exceed 4.7W per channel (i.e., 14W power dissipation for the device). Note that the device can be operated at lower power by reducing the peak to peak video output voltage to less than 50V and clamping the video black level close to the supply voltage.

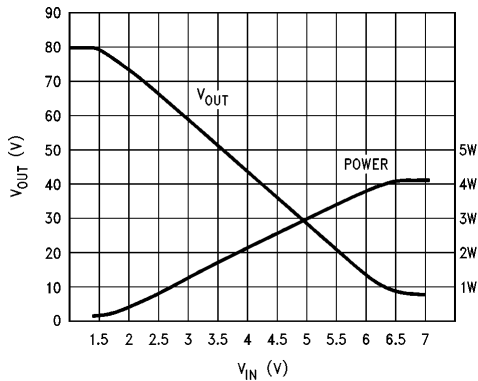

TL/H/11442-10

FIGURE 5. V_{OUT} and Power Dissipation vs V_{IN}

The LM2419 requires that the package be properly heat sunk under all operating conditions. Maximum ratings require that the device case temperature be limited to 90°C maximum. Thus for 50°C maximum ambient temperature and 13W maximum power dissipation, the thermal resistance of the heat sink should be:

$$\theta_{sa} \leq (90-50)^{\circ}\text{C}/13\text{W} = 3^{\circ}\text{C}/\text{W}$$

SHORT CIRCUIT PROTECTION

The output of LM2419 is not short circuit protected. Shorting the output to either ground or to V⁺ will destroy the device. The minimum DC load resistance the LM2419 can drive without damage is 1.6 kΩ to ground or V⁺. However, driving a 1.6 kΩ load for an extended period of time is not recommended because of power dissipation considerations. If the LM2419 is used to drive a resistive load then the load should be 10 kΩ or greater.

RGB Video Application

A complete video section for an RGB CRT monitor is shown in *Figure 6*. The LM1203 video preamplifier and the LM2419 include almost all the circuitry required between the video input connection and the CRT's cathodes. However, an externally generated back porch clamp signal is required to accomplish DC restoration of the video signal.

Figure 6's circuit is excellent choice for a non-interlaced 1024 x 768 display resolution application. With 50 V_{PP} output swing and 12 pF load, the rise/fall time for *Figure 6*'s circuit was measured at 7.5 ns. In this application, feedback is local to the LM1203. For detailed information on the LM1203, please refer to the LM1203 data sheet.

PC BOARD LAYOUT CONSIDERATIONS

For optimum performance, adequate ground plane, isolation between channels, good supply bypassing and minimizing unwanted feedback are necessary. Moreover, the length of the signal trace from the preamplifier to the LM2419 and from the LM2419 to the cathode should be as short as is practical. The following book is highly recommended:

Ott, Henry W, *Noise Reduction Techniques in Electronic Systems*, John Wiley & Sons, New York, 1976.

Application Hints (Continued)

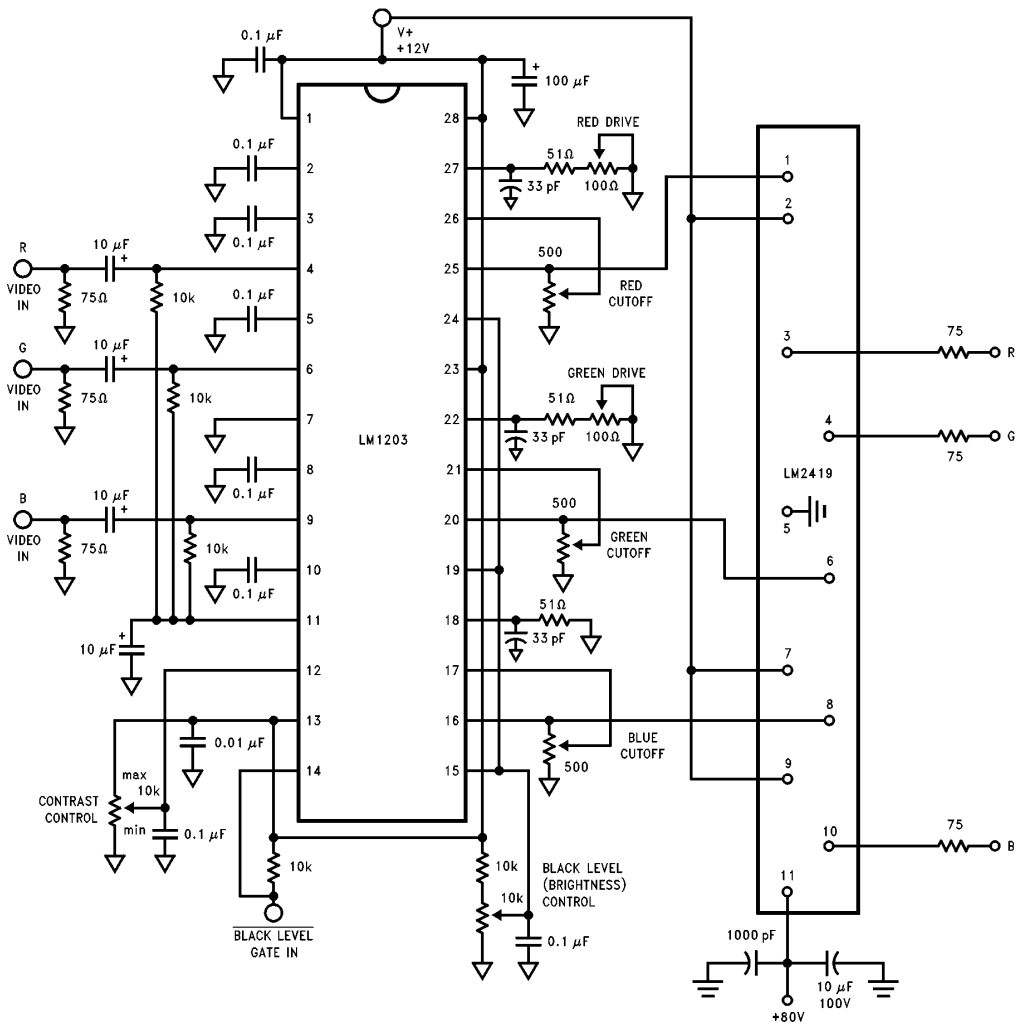
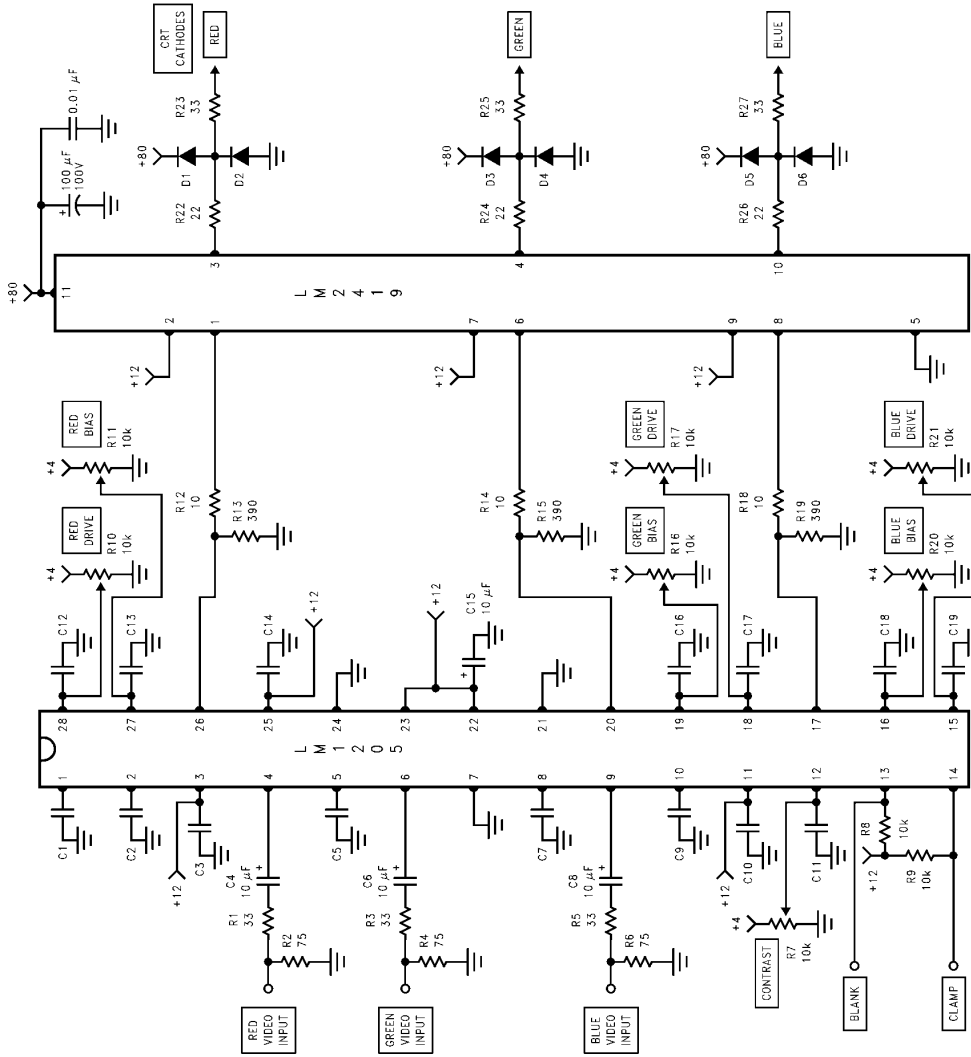

FIGURE 6. Typical VGA/SVGA Application

TL/H/11442-11

Application Hints (Continued)



TL/H/11442-12

Diodes FDH400
Unmarked capacitors 0.1 µF

FIGURE 7. Typical SVGA/XGA Application

This datasheet has been downloaded from:

www.DatasheetCatalog.com

Datasheets for electronic components.